

Roll No

EC-404 (CBGS)**B.Tech., IV Semester**

Examination, May 2019

Choice Based Grading System (CBGS)**Control System***Time : Three Hours**Maximum Marks : 70***Note:** i) Attempt any five questions.

किन्हीं पाँच प्रश्नों को हल कीजिए।

ii) All questions carry equal marks.

सभी प्रश्नों के समान अंक हैं।

iii) In case of any doubt or dispute the English version question should be treated as final.

किसी भी प्रकार के संदेह अथवा विवाद की स्थिति में अंग्रेजी भाषा के प्रश्न को अंतिम माना जायेगा।

1. a) What are open loop and closed loop control system? Give their advantages, disadvantages and applications.

Open loop और closed loop control system क्या है? उनके advantages, disadvantages और अनुप्रयोगों को बताइये।

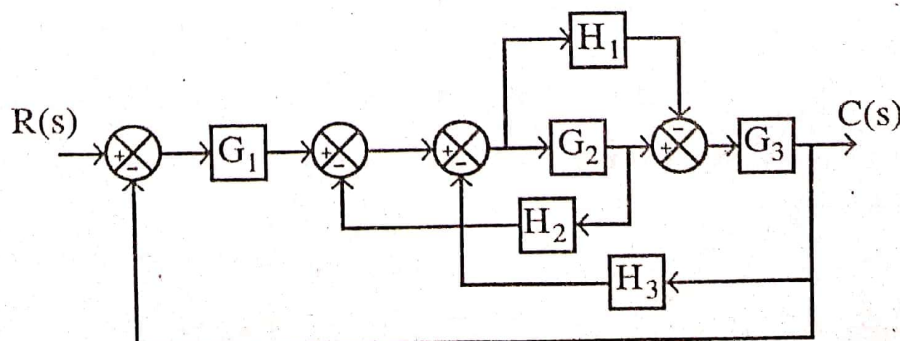
b) Determine $C(s)/R(s)$ by reducing the block diagram for the system given below.नीचे दिये गये system को reduce करके $C(s)/R(s)$ ज्ञात करें।

2. a) Draw the signal flow graph for the following feedback control system.

निम्न दिये गये feedback control system का signal flow graph draw करो।

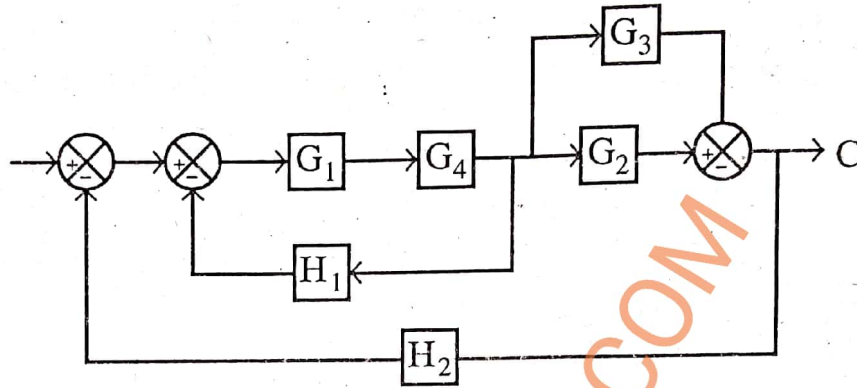

- b) Explain the standard test signals for analyzing the time response of any control system.

किसी control system का time response analyze करने के लिए standard test signals समझाइये।

3. a) A unity feedback system has open loop transfer function as

$$G(s) = \frac{K}{s(s+10)}$$

Determine the value of gain K so that the system will have a damping of 0.5 for this value of K calculate settling time t_s , peak overshoot t_p and maximum overshoot m_p .

एक निम्नलिखित unity feedback system का open loop transfer function है।

$$G(s) = \frac{K}{s(s+10)}$$

K की ऐसी value ज्ञात करें जिससे system की damping 0.5 हो।
और इस K की value से t_s , t_p और m_p ज्ञात करें।

- b) Use Routh Hurwitz criterion to test the stability of a control system whose characteristic equation is given as

$$3s^4 + 10s^3 + 5s^2 + 5s + 2 = 0$$

निम्नलिखित control system की characteristic equation की Routh Hurwitz criterion से stability test करें।

$$3s^4 + 10s^3 + 5s^2 + 5s + 2 = 0$$

4. a) Sketch the complete root locus of the following system. Find the range of K, over which the system is stable.

निम्न में दिये गये system का complete root locus sketch करें और K का range निकालें जिसमें system stable है।

$$G(s)H(s) = \frac{K}{s(s+1)(s+2)(s+3)}$$

- b) With the help of diagram explain phase margin and gain margin.

चित्र की सहायता से phase margin और gain margin समझाइए।

5. a) Draw and explain Bode plot with an example.

उदाहरण के साथ Bode plot समझाइये व diagram बनाइए।

- b) Apply the Nyquist criterion to the following open loop transfer function

निम्न दिए गये open loop transfer function पर Nyquist criterion apply करें।

$$G(s)H(s) = \frac{4s+1}{s^2(1+s)(1+2s)}$$

6. a) Draw the diagram of lead compensator and find the expression for its transfer function.

Lead compensator का diagram बनाइये और उसके transfer function का expression ज्ञात करें।

- b) Explain in brief proportional, derivative, integral and composite controllers.

Proportional, derivative, integral और composite controllers समझाइये।

7. a) Explain the concept of observability and controllability applied to control system.

Observability और Controllability जो कि control system पर लागू होता है उसका concept समझाइये।

- b) Obtain a state space model for the system whose transfer function is

निम्न system transfer function का state space model बनाइये।

$$\frac{Y(s)}{R(s)} = \frac{(s+2)}{(s+1)(s+3)}$$

8. Write short notes on any two of the following.

निम्नलिखित में से किन्हीं दो पर short notes लिखें।

- a) Effect of feedback on control system and external disturbance
 b) Effect of location of poles on stability
 c) Correlation between time and frequency response
 d) Relationship between state equation and transfer function
